

Quick Start Guide

Gigabit Ethernet to Coax bridge

GLinq GL-I-1GE-1C

1. Unpack and Check Contents



GL-I-1GE-1C
Indoor GEto G.hn Coax Bridge AP



12 VDC Power Supply



QSG will be posted to the Web



Wall Mounting Kit

2. Mount the Bridge AP

a. Mounting on a Wall

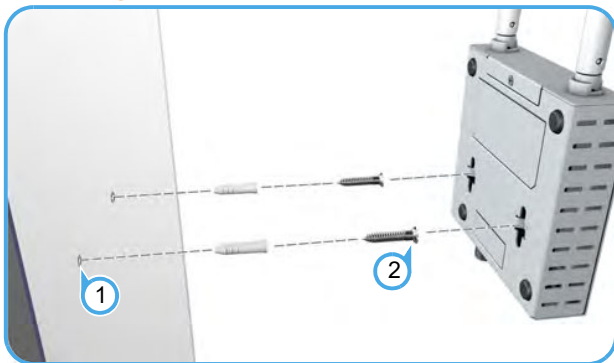

- 1 In the required location, mark and drill two holes spaced 57 mm apart in the wall for M4 wall anchors.

Note: For a wood wall, drilling holes and using wall anchors is not required.

- 2 Mount the unit on the wall and secure it in place using two M4 x20 tapping screws.

b. Mounting on a Desktop

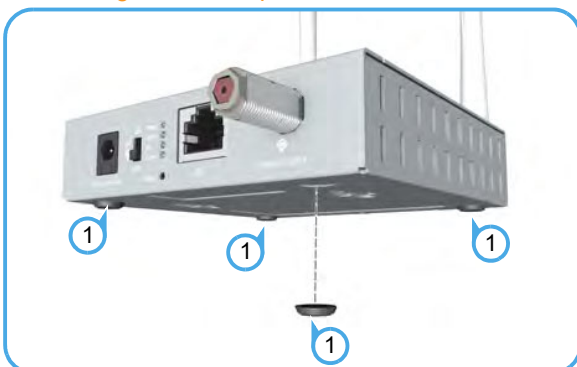

- 1 Attach the included four rubber feet to the base of the bridge AP and place the bridge AP on the desktop.

3. Connect Power

The bridge AP can receive power from one of two different power sources:

- The supplied DC power adapter to the DC power jack.
- Power over Coaxial cable (PoC) to the F-type coaxial connector (from another IgniteNet GLinq only).

a. DC Power Jack

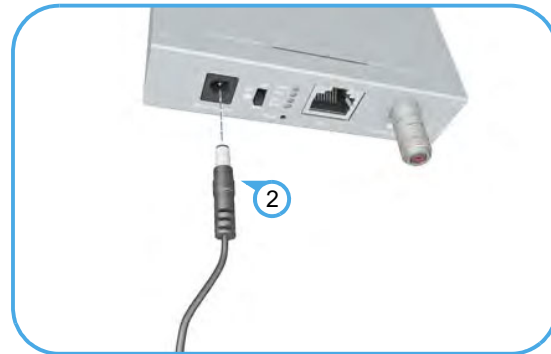

- 1 Plug the DC power supply into a suitable power mains outlet.
- 2 Insert the DC power supply DIN connector into the bridge AP's DC power jack.

Note: When power is supplied to the DC jack and the DC switch is set to ON, the F-type coaxial connector functions as a 12 VDC PoC power source.

b. PoC Power



Warning: Before connecting a coaxial cable with power to the bridge AP, ensure the PoC DC switches are in the OFF position on both the PoC source bridge AP and the PoC receive bridge AP.



Caution: To prevent damage when physically connecting a coaxial cable, follow the instructions in step: [7. Connect Coaxial Cable](#)

- 1 Using the DC jack, connect power to the bridge AP that is to supply coaxial cable power.
- 2 On both the power source and receive bridge APs connect a coaxial cable. Refer to step: [7. Connect Coaxial Cable](#) of this guide on how to connect coaxial cable connectors.

- On the bridge AP that is to supply power, slide the PoCDC switch to the ON position.

4. Verify Bridge AP Operation

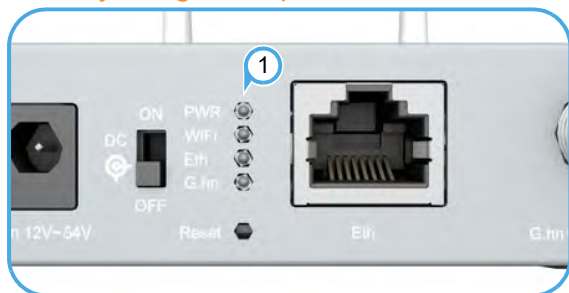

- Verify basic switch operation by checking the system LEDs. When operating normally, the Power LED should be on green, and the WiFi, Eth and G.hn LEDs should be on or blinking green.

5. Connect an Ethernet Cable



- Connect Category 5e or better cable to the RJ-45 port.
- As the connection is made, check the Ethernet port status LED to be sure the link is valid:
 - On Green — Port has a valid link.
 - Blinking Green — Indicates network activity.

6. Connect a Coaxial Cable



Caution: Damage may occur if an F-type cable connector on the G.hn is overtightened. Do not tighten a connector more than the maximum torque rating of 168 N-cm (16 lb-in).

Note: Use only threaded male F-type compression coaxial cable connectors to connect coaxial cable between the bridge APs.

Note: It is NOT recommended to use Flex F or push-on connectors. Always use standard threaded male F-connectors.

- Screw a male coaxial cable connector onto the bridge AP F-type coaxial connector until it is finger tight. If you are using a specialized torque wrench, tighten the connector to the maximum specified torque of:
 - 168 N-cm or 16 lb-in
- As the connection is made, check the G.hn port status LED to be sure the link is valid:
 - On Green — Port has a valid link.
 - Blinking Green — Indicates network activity.

7. Verify AP Operation

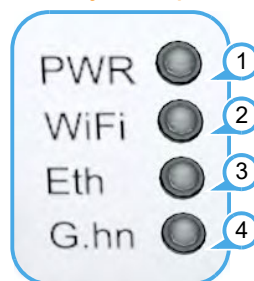

- Power LED, cloud status, gateway status—
 - power connected (on)
 - no power connected (off)
- WiFi—
 - radio enabled (on)
 - radio disabled (off)
 - link activity (blinking)
- Ethernet —
 - plugged wire (on)
 - unplugged wire (off)
 - link activity (blinking)
- G.hn —
 - coaxial cable connected (on)
 - coaxial cable disconnected (off)
 - link activity (blinking)

8. Complete the Device Configuration

a. Manage the AP with the IgniteNet Cloud Controller

Go to <https://cloud.ignitenet.com> to register your AP. Log in and select Devices from the menu. Click Add Device and enter the AP serial number and MAC address to register the AP with your cloud network. (The serial number and MAC address can be found on the product packaging or label.)

b. Manage the AP in Stand-Alone Mode (Optional)

To access the web interface, connect a PC directly to the AP's Eth RJ-45 port. In a web browser, enter the AP's default management IP address of 192.168.1.20 to access the web login page.



Log in to the web interface using the default settings:

- ◆ Login Name — root
- ◆ Password — admin123

If you select to manage the AP in stand-alone mode, use the web interface to manually make your configuration changes.

For more information on AP configuration in stand-alone mode, refer to the Helios User Manual, which can be downloaded from: <https://support.ignitenet.com>

Note: To reset the Bridge AP to factory default settings, press and hold down the AP's Reset button for 5 seconds. A quick press of the Reset button reboots the AP.

Safety and Regulatory Information

FCC Class B

This equipment has been tested and found to comply with the limits for a Class B digital device, pursuant to Part 15 of the FCC Rules. These limits are designed to provide reasonable protection against harmful interference in a residential installation. This equipment generates, uses and can radiate radio frequency energy and, if not installed and used in accordance with the instructions, may cause harmful interference to radio communications. However, there is no guarantee that interference will not occur in a particular installation. If this equipment does cause harmful interference to radio or television reception, which can be determined by turning the equipment off and on, the user is encouraged to try to correct the interference by one of the following measures:

- ◆ Reorient or relocate the receiving antenna
- ◆ Increase the separation between the equipment and receiver
- ◆ Connect the equipment into an outlet on a circuit different from that to which the receiver is connected
- ◆ Consult the dealer or an experienced radio/TV technician for help

FCC Caution: Any changes or modifications not expressly approved by the party responsible for compliance could void the user's authority to operate this equipment.

This device complies with Part 15 of the FCC Rules. Operation is subject to the following two conditions: (1) This device may not cause harmful interference, and (2) this device must accept any interference received, including interference that may cause undesired operation.

For product available in the USA/Canada market, only channel 1–11 can be operated. Selection of other channels is not possible.

IMPORTANT NOTE

FCC Radiation Exposure Statement:

This equipment complies with FCC radiation exposure limits set forth for an uncontrolled environment. This equipment should be installed and operated with minimum distance 20 cm between the radiator and your body.

Industry Canada

This device complies with Industry Canada license-exempt RSS standard(s). Operation is subject to the following two conditions: (1) this device may not cause interference, and (2) this device must accept any interference, including interference that may cause undesired operation of the device.

Le présent appareil est conforme aux CNR d'Industrie Canada applicables aux appareils radio exempts de licence. L'exploitation est autorisée aux deux conditions suivantes : (1) l'appareil ne doit pas produire de brouillage, et (2) l'utilisateur de l'appareil doit accepter tout brouillage radioélectrique subi, même si le brouillage est susceptible d'en compromettre le fonctionnement.

For product available in the USA/Canada market, only channel 1~11 can be operated. Selection of other channels is not possible.

Pour les produits disponibles aux États-Unis/ Canada du marché, seul le canal 1 à 11 peuvent être exploités. Sélection d'autres canaux n'est pas possible.

CE Mark

CE Mark Declaration of Conformance for EMI and Safety (EEC)

This information technology equipment complies with the requirements of the Council Directive 2014/30/EC on the Approximation of the laws of the Member States relating to Electromagnetic Compatibility and 2014/35/EC for electrical equipment used within certain voltage limits. For the evaluation of the compliance with these Directives, the following standards were applied:

IMPORTANT NOTE:**IC Radiation Exposure Statement:**

This equipment complies with IC RSS-102 radiation exposure limits set forth for an uncontrolled environment. This equipment should be installed and operated with minimum distance 28 cm between the radiator and your body.

Cet équipement est conforme aux limites d'exposition aux rayonnements IC établies pour un environnement non contrôlé. Cet équipement doit être installé et utilisé avec un minimum de 28 cm de distance entre la source de rayonnement et votre corps.

CE Statement

This equipment complies with EU radiation exposure limits set forth for an uncontrolled environment. This equipment should be installed and operated with minimum distance 20 cm between the radiator and your body.

All operational modes:

2.4 GHz: 802.11b, 802.11g, 802.11n (HT20), 802.11n (HT40)

The frequency and maximum transmitted power limit in EU are listed as below:

2412-2472 MHz: 20 dBm

低功率電波輻射性電機管理辦法

第十二條 經型式認證合格之低功率射頻電機，非經許可，公司、商號或使用者均不得擅自變更頻率、加大功率或變更原設計之特性及功能。

第十四條 低功率射頻電機之使用不得影響飛航安全及干擾合法通信；經發現有干擾現象時，應立即停用，並改善至無干擾時方得繼續使用。前項合法通信，指依電信法規定作業之無線電通信。低功率射頻電機須忍受

受合法通信或工業、科學及醫療用電波輻射性電機設備之干擾。

Warnings and Cautionary Messages

Warning: This product does not contain any serviceable user parts.



Warning: Installation and removal of the unit must be carried out by qualified personnel only.

Warning: The F-type Coaxial Connector can conduct up to 2.5 amperes of DC current if power is supplied to the unit and its DC switch is in the ON position.

Warning: If applying DC voltage to a coaxial cable using the GLinq, you must ensure that all connected devices are capable of sustaining a DC voltage applied to their coaxial input without damage.

Caution: Wear an anti-static wrist strap or take other suitable measures to prevent electrostatic discharge when handling this equipment.



Caution: Do not plug a phone jack connector in the RJ-45 port. This may damage this device.

Caution: Use only twisted-pair cables with RJ-45 connectors that conform to FCC standards.

**Europe - EU Declaration of Conformity**

Hereby, IgniteNet Inc. declares that the radio equipment type: Indoor Gigabit Ethernet to G.hn Coax. Bridge AP w/PoC GL-I-1GE-1C is in compliance with Directive 2014/53/EU.

The full text of the EU declaration of conformity is available at the following Internet address:

www.ignitenet.com -> support.

Hardware Specifications

Chassis

Size (WxDxH) 131 x 100 x 26 mm (35.16 x 3.94 x 1.02 in)

Weight 277 g (0.61 lb)

Temperature Operating: 0° C to 50° C (32 F to 122° F)
Storage: -40° C to 70° C (-40° F to 158° F)

Humidity Operating: 5% to 90% (non-condensing)

Network Ports

- ◆ One 1000BASE-T RJ-45 PoE port
- ◆ One 2 Gbps G.hn F-type Coaxial Connector

Status LEDs Power, Wireless 2.4 GHz, Ethernet, G.hn

Power

DC Input Power 12 – 54 VDC, 1.0 A

Coaxial Cable Input Power 12 VDC, 1.0 A

Maximum Coaxial Cable Output Current 2.5 A

Power Consumption 6.5 W maximum

Standards

Ethernet IEEE 802.3ab 1000BASE-T

Wireless IEEE 802.11b/g/n 2.4 GHz with 2x2 MIMO
G.hn Coax. ITU-T G.hn G.9960, G.9961 bandplan: 25 MHz, 50 MHz, 100 MHz, 200 MHz (max. 2 Gbps)

Regulatory Compliance

Radio Frequencies 2412–2472 (FCC, IC, CE, AU, MIC, NCC, SRRC)

Immunity EN 55024:2010
IEC 61000-4-2/3/4/5/6/8/11

Manufacturer Accton Technology Corporation
1, Creation 3rd Rd., Hsinchu Science Park,
Hsinchu 30077,
Taiwan, R.O.C