



### Key Features

- IEEE 802.11ac and IEEE 802.11 a/b/g/n compliant
- Up to 300Mbps (2.4GHz) + 867Mbps (5GHz) wireless data transmission rate
- Gigabit Ethernet port with IEEE 802.3 standard PoE support
- Ceiling mount housing and internal antennas for low-profile design
- Web-based and EZ controller software for easy configuration
- AP/WDS mode support
- SNMP V1/ V2c/V3, MIB I/II supported
- WEP/WPA/WPA2 wireless encryption
- IPv4/IPv6 support
- Effective and flexible bandwidth management
- Band steering, guest network, client limit, fast roaming, and client status support

### 802.11a/b/g/n/ac Dual Radio Concurrent Ceiling Mount AP

---

#### **State-of-the-art 802.11ac brings revolutionary connection speed on your WLAN for diversity of multimedia applications**

EAP1200H equips with two powerful independent RF interfaces that support 2.4GHz 802.11b/g/n (2T2R) and 5GHz 802.11a/n/ac (2T2R), offering bandwidth up to 300Mbps + 867Mbps to accommodate traffic-intensive applications such as multimedia streaming.

#### **Enhanced Signal Strength to Further Extend WLAN Coverage**

Each radio of EAP1200H has been enhanced to provide higher signal strength and receive sensitivity; this will assist to reduce dead spots in your deployed WLAN and boost received signal quality on both ends of AP and wireless client devices.

## 802.3at-compliant Power- over-Ethernet (PoE) for Second Power Sourcing Alternative

EAP1200H can be powered by enclosed power adapter or off-the-shelf 802.3at-compliant PoE switches; solving common power sourcing issue in the field where devices are usually placed at drop-ceiling or mounted on walls.

## Multiple Operation Modes for Versatile Applications

Each radio of EAP1200H can independently operate in 3 different modes, namely **Access Point, WDS AP, or WDS Bridge**; this will allow multiple combinations of operation modes on single device to address deployment requirements.

## Configuration and Management with Ease

Besides intuitive web-based management, EnGenius EZ Controller software utility provides user extra convenience on applying various configuration settings into devices, enabling prompt WLAN deployment and configuration update.

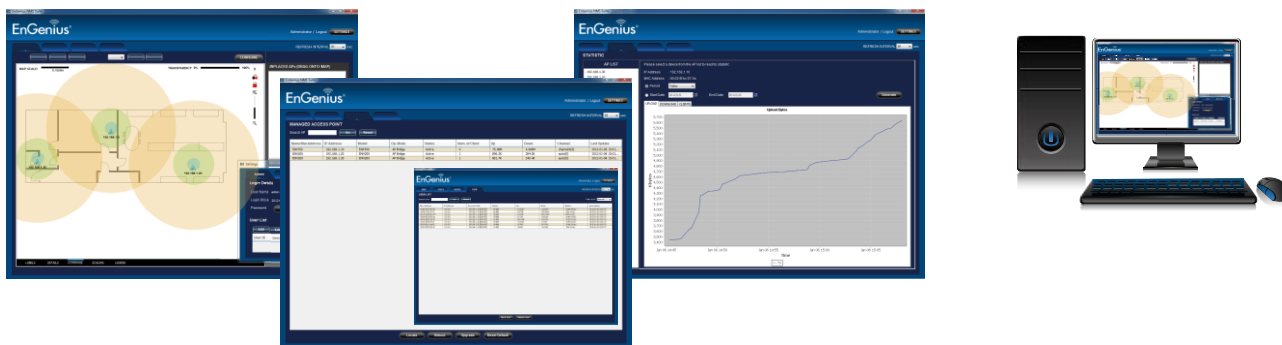

## Advanced WLAN Features to Facilitate Smooth Roaming and Effective Spectrum Usage

For effective spectrum usage, EAP1200H has enclosed band steering technology in high-capacity environment, enabling 5GHz-capable clients to associate with its 5GHz radio and offloading air utilization in 2.4GHz-band. In addition, EnGenius fast roaming minimizes service down-time during handoff from one base station to another.

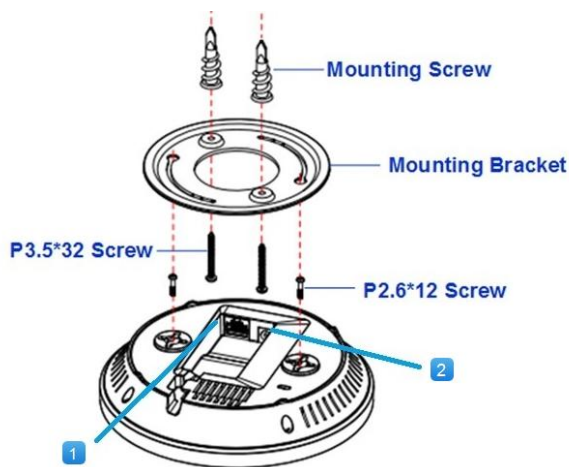

## Physical Interface

1. LAN Port (802.3at PoE)
2. Power Connector

## Technical Specifications

### Radio Specification

- Dual Concurrent Radio
  - 2.4GHz: 802.11b/g/n with max data rate up to 300Mbps
  - 5GHz: 802.11 a/n/ac with max data rate up to 867Mbps
- Transmit Power (combined):
  - 2.4GHz: max 26dBm
  - 5GHz: max 26dBm
  - Maximum transmit power is limited by regulatory power
- Radio Chains / Spatial Streams: 2 x 2 : 2
- Supported Radio Technology:
  - 802.11b: direct-sequence spread-spectrum (DSSS)
  - 802.11a/g/n/ac: orthogonal frequency-division multiplexing (OFDM)
- Channelization
  - 802.11ac with 20/40/80 MHz channel width
  - 802.11n with 20/40 MHz channel width
  - 802.11a/b/g with 20 MHz channel width
- Supported Modulation:
  - 802.11b: BPSK, QPSK, CCK
  - 802.11a/g/n: BPSK, QPSK, 16-QAM, 64-QAM
  - 802.11ac: BPSK, QPSK, 16-QAM, 64-QAM, 256-QAM
- Supported data rates (Mbps):
  - 802.11b: 1, 2, 5.5, 11
  - 802.11a/g: 6, 9, 12, 18, 24, 36, 48, 54
  - 802.11n: 6.5 to 300 (MCS0 to MCS15)
  - 802.11ac: 6.5 to 867 (MCS0 to MCS9, NSS = 1 ~ 2)

### Physical Characteristics

- Power Source:
  - DC Input: 12 VDC 2A
  - PoE: compatible with 802.3at
- Internal High Gain Antennas
  - 2 x 5dBi 2.4GHz antennas
  - 2 x 5dBi 5GHz antennas
- Interface
  - 1 x 10/100/1000 BASE-T Ethernet (RJ45) with 802.3at PoE
  - 1 x DC power connector
  - 1 x reset button
- Dimensions / Weight
  - 161.5 x 41.5mm (Diameter x Height)
  - 290g
- Mounting
  - Ceiling mount or wall mount
- Physical Security
  - Kensington security slot

### Wireless

- Operating Mode: AP / WDS
- Auto Channel Selection
  - Setting varies by regulatory domains
- SSIDs:
  - Supports up to 8 SSIDs per frequency band
- VLAN Tag / VLAN Pass-through
- Wireless Client List
- Guest Network
  - Allocates a separate network segment for guest access within the same WLAN
- QoS
  - Supports 802.11e/WMM/Traffic Shaping
- Band Steering
  - Moves 5GHz-compatible clients to 5GHz band to ease traffic congestion on 2.4GHz band
- Fast Roaming
  - Short client roaming time between APs 50ms
- Mobility
  - PMKSA support for fast roaming
- Security
  - WEP encryption: 64/128/152-bit
  - WPA/WPA2 Enterprise/PSK
  - Hidden SSID
  - MAC address filtering (up to 50 MAC)
  - Station separation

### Management

- Configuration
  - Web interface (HTTP/S)
  - SNMP v1/v2c/v3 with MIB I/II and private MIB
  - CLI (Telnet/SSH)
- Firmware Upgrade
  - Web interface or CLI
- Backup / Restore Settings
  - Revert to factory default settings
- Save Configuration as Default:
  - Saves the customized configuration as default
- Auto Reboot
  - Specifies interval to reboot system periodically
- E-mail Alert / Syslog Notification
  - Provides a network monitoring tool for administrators to stay informed upon configuration change or network errors

### Environment

- Operating temperature: 0°C~40°C
- Operating humidity: 0%~90% typical
- Storage temperature: -20°C~60°C

## RF Performance Table

Channel	Data Rate	Transmit Power (Combined, dBm)	Receive Sensitivity (Combined, dBm)
802.11b 2.4 GHz	1 Mbps	26.0	-92.0
	2 Mbps	26.0	-91.0
	5.5 Mbps	26.0	-91.0
	11 Mbps	26.0	-89.0
802.11g 2.4 GHz	6 Mbps	25.0	-88.0
	54 Mbps	22.0	-72.0
802.11a 5 GHz	6 Mbps	26.0	-90.0
	54 Mbps	23.0	-72.0
802.11n HT20 2.4 GHz	MCS 0 / 8	25.0	-88.0
	MCS 7 / 15	22.0	-69.0
802.11n HT40 2.4 GHz	MCS 0 / 8	25.0	-84.0
	MCS 7 / 15	21.0	-68.0
802.11n HT20 5GHz	MCS 0 / 8	26.0	-89.0
	MCS 7 / 15	22.0	-70.0
802.11n HT40 5GHz	MCS 0 / 8	26.0	-85.0
	MCS 7 / 15	21.0	-68.0
802.11ac VHT20 5GHz	MCS0	25.0	-88.0
	MCS8	19.0	-65.0
802.11ac VHT40 5GHz	MCS0	25.0	-85.0
	MCS9	17.0	-61.0
802.11ac VHT80 5GHz	MCS0	25.0	-82.0
	MCS9	17.0	-58.0

\*Maximum transmit power is limited by local regulation.

\*The supported frequency band is restricted by local regulatory requirements.

\*Transmit power is configurable in 1.0dB increments.

## Antenna Radiation Patterns (Internal Antenna)

### 2.4GHz Azimuth-Plane

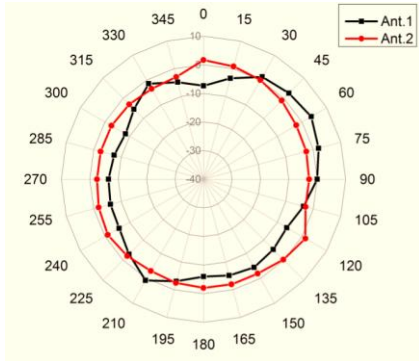

### 2.4GHz Elevation-Plane

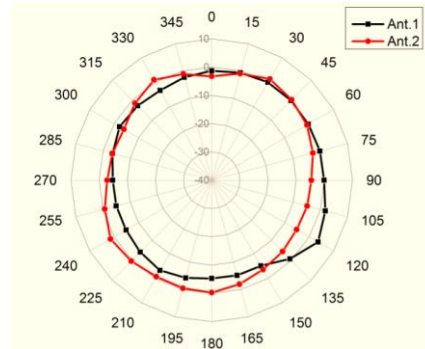

### 5GHz Azimuth-Plane

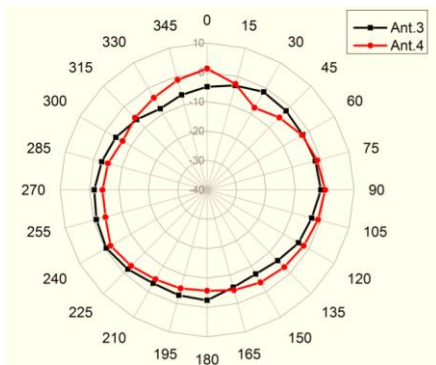

### 5GHz Elevation-Plane

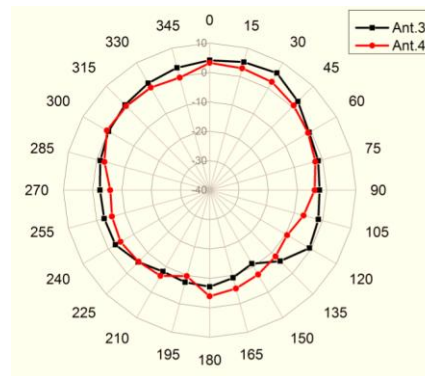

Maximum data rates are based on IEEE 802.11 standards. Actual throughput and range can vary depending on many factors including environmental conditions, distance between devices, radio interference in the operating environment, and mix of devices in the network. Features and specifications subject to change without notice. Trademarks and registered trademarks are the property of their respective owners.  
Copyright © 2013 EnGenius. All rights reserved.